

## Technical Features

# Save time!

With reusable Milk Filters

# Save money!

No messy Milk Socks

Save over £120/€190 per year in an average herd of 50-100 cows

The Ambic Flowfilter is designed to last for years with a comprehensive range of spares and is considerably cheaper to run than any milk filter using disposable filter socks.

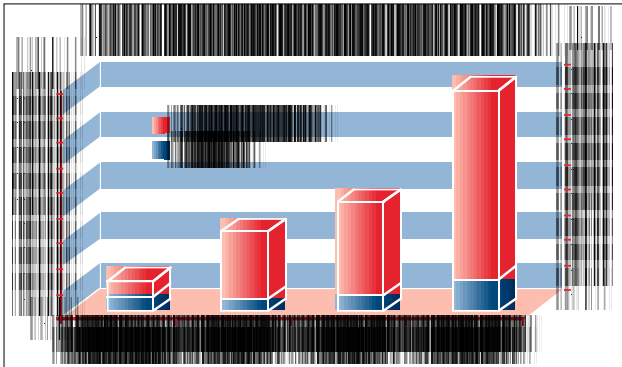

\* Based on average RRP

A key component in any milking system particularly those incorporating a Plate Cooler

### Part Numbers:

AF/010	Flowfilter complete
AF/001	Set of 'O' Rings and Seals
AF/002	Pair of Filters
AF/005	Inner Filter
AF/006	Outer Filter
AF/008	Case Only
AF/009	Quick Release Case Tool

AMBIC: A Healthy Herd • A Healthy Profit

# AMBIC

...designed for today's Dairy Farmer

Other world class products in the Ambic range:-



### Jetstream

The world's most advanced high power, vacuum operated Teat Spray system. Fully expandable, to meet the needs of even the largest herds.



### Vision

Installed in minutes, this robust 2nd generation in line detector provides guaranteed individual mastitis detection 365 days of the year.



NEW PRODUCT

### Milk Sampler

Developed with NMR, this stand alone sampler takes a small yet representative sample across the whole milking.



### Dip Cups

Acclaimed by dairymen world-wide as the best you can get, the Ambic range is globally recognised as the brand leader.

YOUR LOCAL AMBIC DEALER:



Ambic Equipment Limited  
Avenue Four, Station Lane, Witney  
Oxfordshire, OX28 4XT. England  
Telephone: +44 (0) 1993 776555  
Fax: +44 (0) 1993 779039  
Email: sales@ambic.co.uk



FM 09784

Visit the Ambic web site: [www.ambic.co.uk](http://www.ambic.co.uk)

SHEET No FF6400 1/11/02

AMBIC: A Healthy Herd • A Healthy Profit

# AMBIC

## FLOWFILTER



# Save time!

# Save money!

The simplest way to filter milk

AMBIC: A Healthy Herd • A Healthy Profit

## Ambic Flowfilter

*The proven technology of the Ambic Flowfilter gives unsurpassed milk filtration, without the inconvenience and cost of disposable milk socks.*

- Twin stainless steel milk filters, that won't rust or corrode
- New tinted case with seamless construction and slip resistant grips
- Designed and manufactured from the highest quality chemical resistant materials
- Superior filter complies with BS 5190 and all EU standards
- Fully compatible with all milking systems
- Protects plate coolers from blockages
- Proven over 20 years of service
- Full range of spare parts available

*For over 20 years Ambic Equipment Limited has developed and manufactured a range of Filtration, Mastitis Detection and Teat Disinfection Equipment that serves the needs of the world's leading Dairy Farmers.*

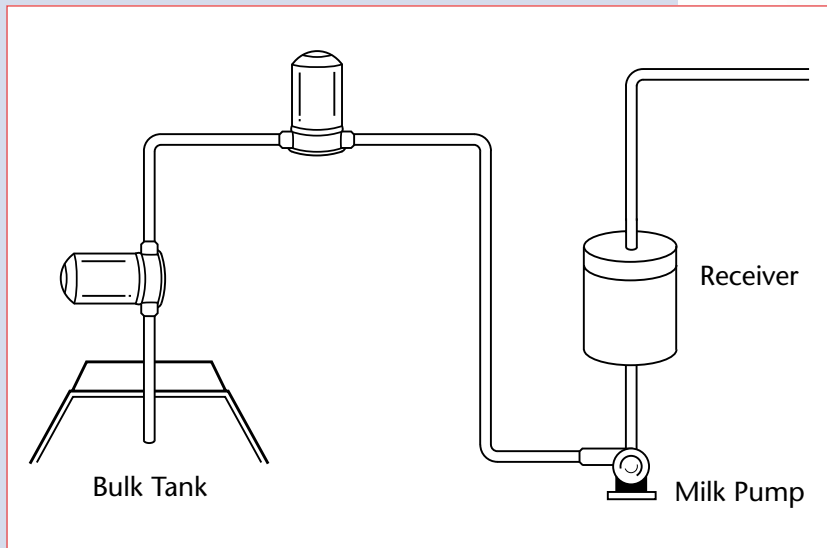

*Flowfilter fits any stage of transfer line*